

## TRAILER COVER INSTALLATION INSTRUCTIONS





## NB! Wear protective gloves and safety glasses during installation!

**Tools needed:** 10mm and 13mm socket and wrench; 4mm hex key; knife; 10,5mm, 7mm drill bit and drill.

1. Start the installation by placing the plastic cover upside down on the floor. Use a blanket or cardboard under the cover to avoid dents and scratches! **See figure 1.**

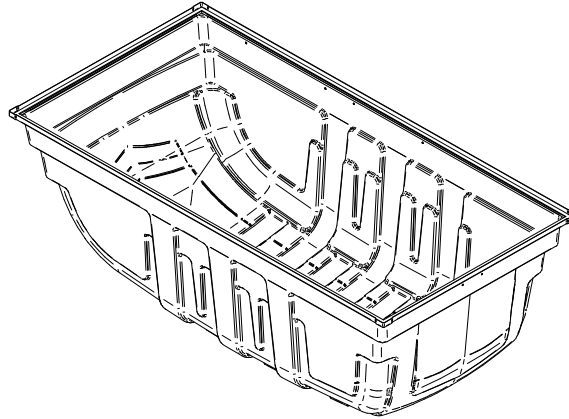

Figure 1

2. Holes for hinges and handle are predrilled on the cover.
3. All needed components and fasteners can be found in the accessory bag.
4. Install 8 rubber grommets to hinge holes on both sides as shown below. **See figure 2.**  
**NB!** Check the grommet placement with dimensions shown on **figure 3.**

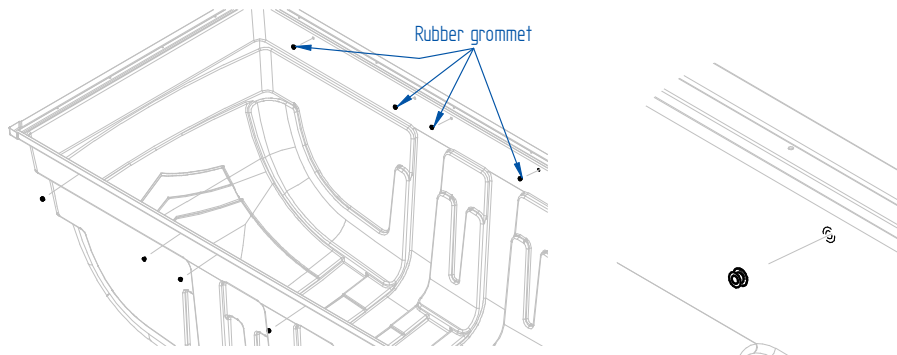

Figure 2

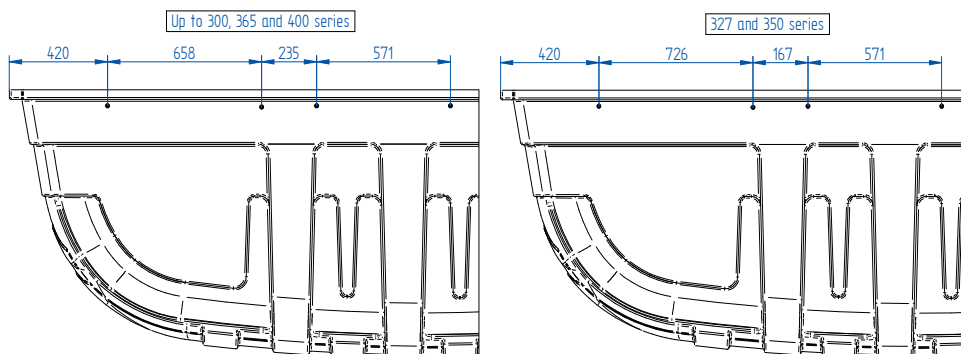

Figure 3



5. Clean the metal frame inside the cover and install the self-adhesive seal on the frame (figures 4 and 5). Do not stretch the seal during fastening!

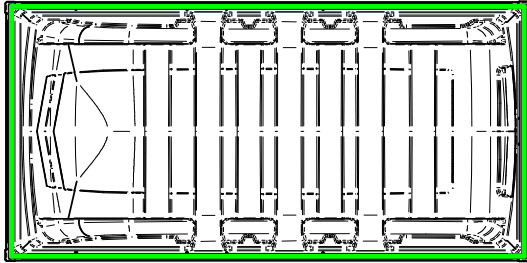

Figure 4

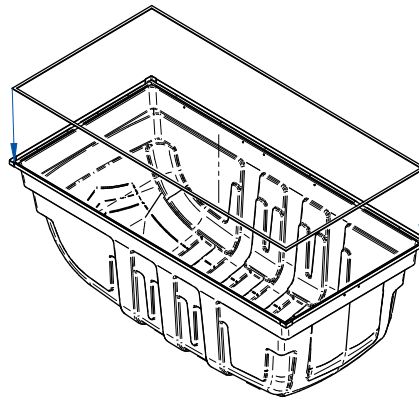

Figure 5

6. Fasten the handle to the back wall of the cover through the predrilled holes. Use M6x25 bolts + M6 Nylock flanged nuts. Also fasten the down pulling strap under one of the nuts. Use M8x25 washer like shown in figure 6.

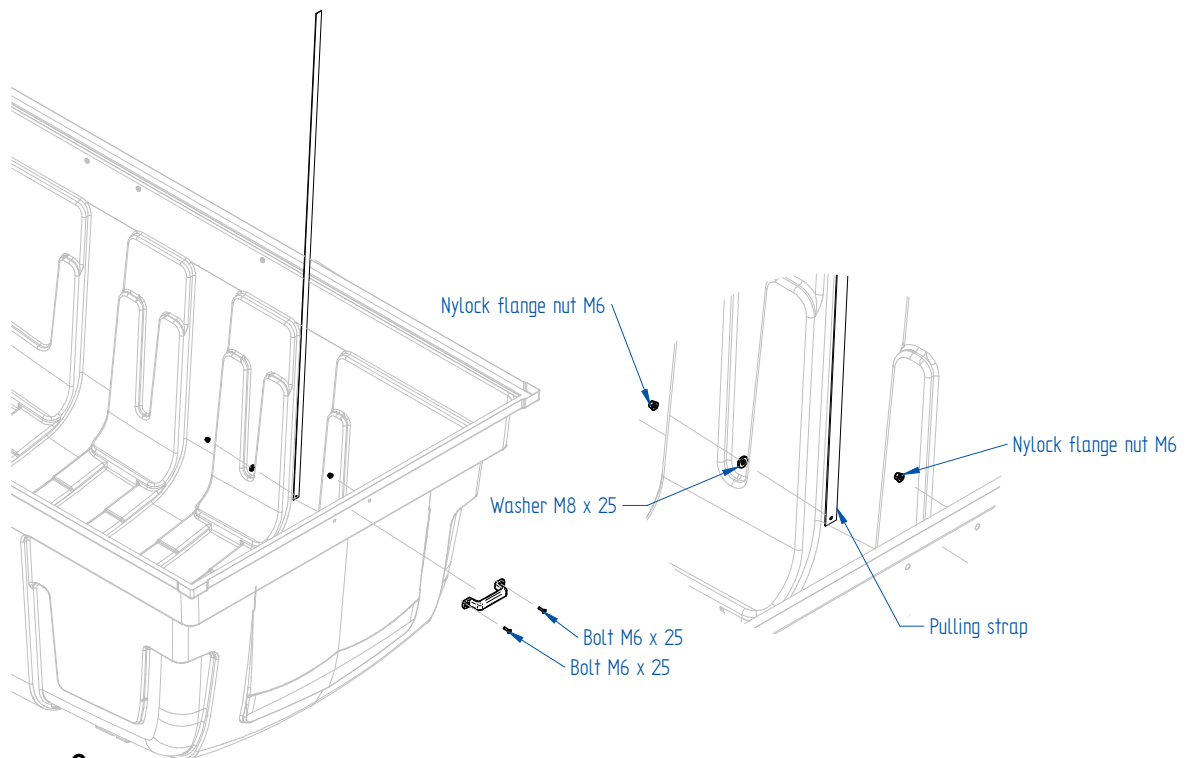

Figure 6



7. Hinge installation to plastic cover.

7.1. On up to **300 series**, fasten the **right** and **left** hinge to the plastic cover using M8x50 bolts + M8x25 washers + M8 flange nuts. At the position A, also install a bushing (**Figure 7**). Use washers under bolt head and flange nuts on the inside (**figures 8**)

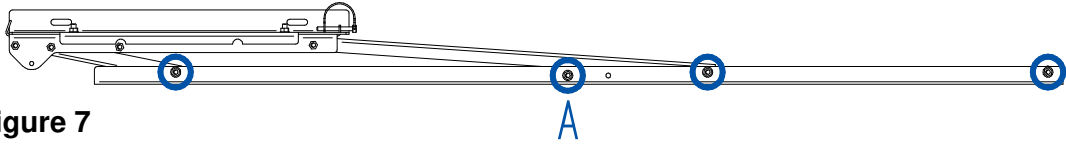

Figure 7

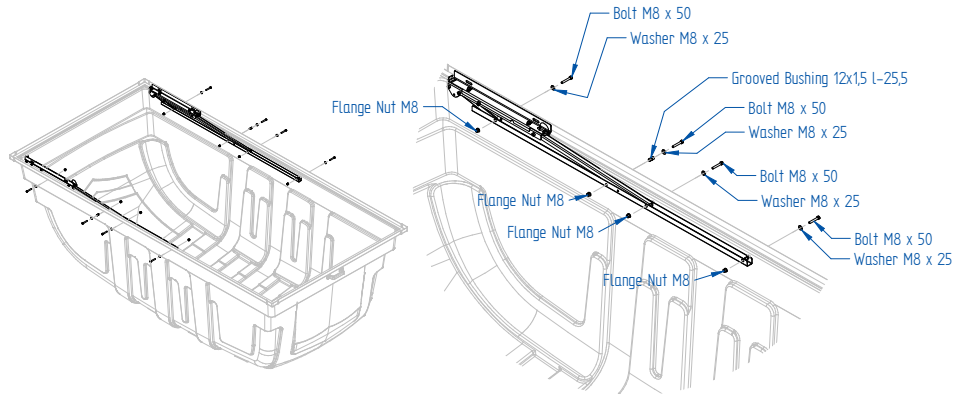

Figure 8

7.2. On **327 and 350 series**, fasten the **right** and **left** hinge to the plastic cover using M8x50 bolts + M8x25 washers + M8 flange nuts. At the position A, also install a bushing (**Figure 9**). Use washers under bolt head and flange nuts on the inside (**figures 10**)

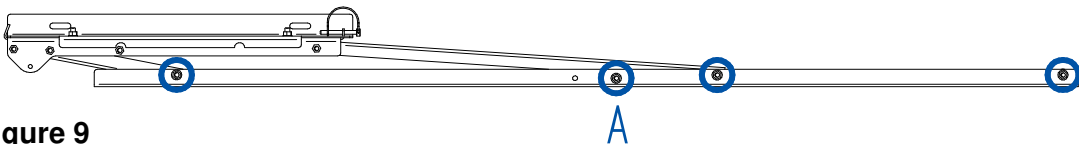

Figure 9

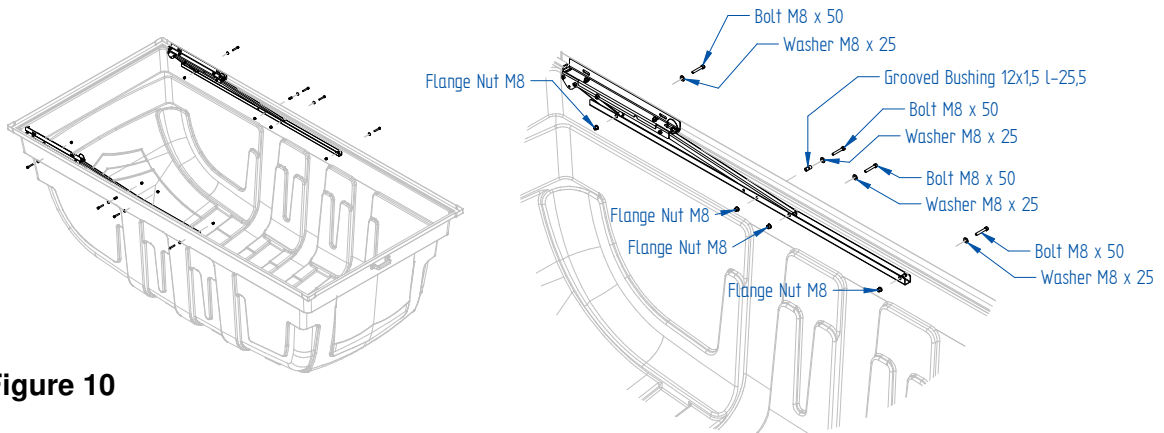

Figure 10



### 7.3.365 and 400 series hinge installation

7.3.1. On the lower part of the hinge, remove the M8x40 bolt and replace it with a M8x70. On the bolt install a second grooved pushing and fasten with M8 nylock flange nut. See figure 11.

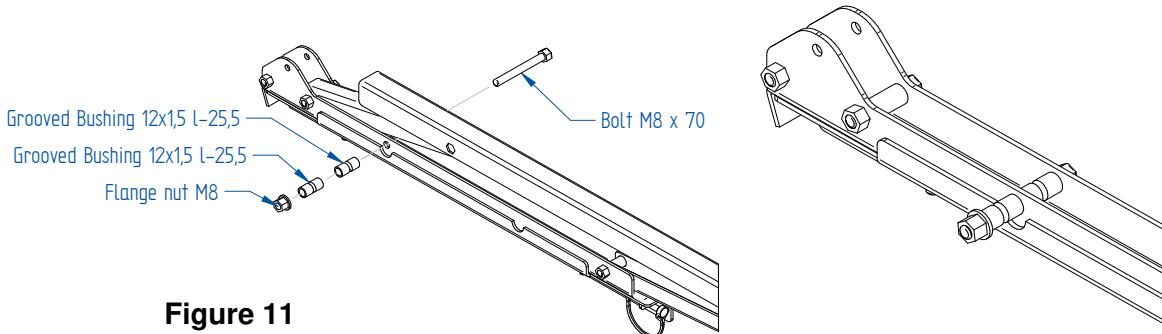

Figure 11

7.3.2. Fasten the **right** and **left** hinge to the plastic cover using M8x50 bolts + M8x25 washers + M8 flange nuts. At the position A, also **install 2 bushings** (Figure 12). Use washers under bolt head and flange nuts on the inside (figures 13)

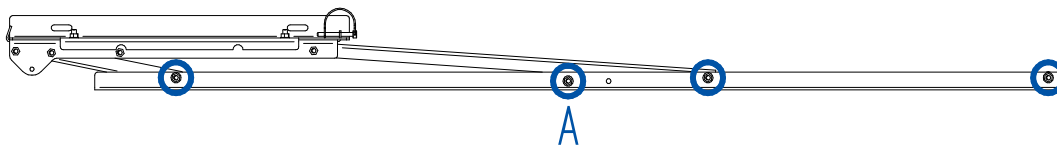

Figure 12

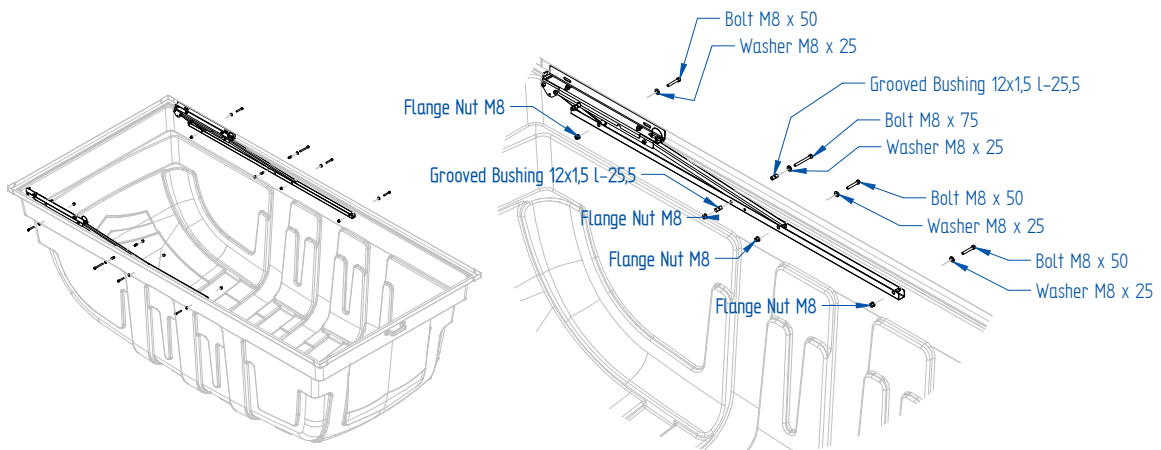

Figure 13



8. Open / remove trailers front hatch.
9. Lift the trailer cover on top of trailer.
10. Align the cover to the trailer lengthwise and crosswise.
11. Check that the cover sits tight on the trailer. If not, use clamping screws or cargo straps to fix the ends of the cover to trailer edges. Applying opposite pressure to the curvature of the cover if necessary.
12. Through the open front hatch align upper and lower hinge part so that they are parallel and make sure the markings are in the center of the oval cutouts **(figure 14)**.  
If there are no markings, align the upper and lower hinge parts parallel and mark the positions on the port in the center of the hinge ovals.

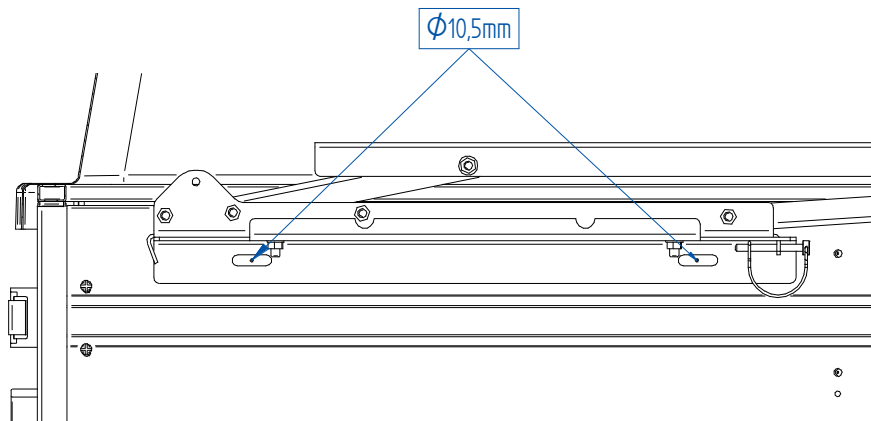

Figure 14

13. Drill holes through the boards in the center of the markings using D10,5 mm drill.
14. Fasten hinges using M10x25 flange bolts + M10x25 washers + M10 Nylock nuts. Use washers only under nuts. Leave bolt head outside of trailer.
15. Open the trailer cover.  
**ATTENTION!** At this point, since springs are not yet installed, it is heavy to open, and cover does not stay open, until it is fully open. Use safety splints **(Figure 15)**!

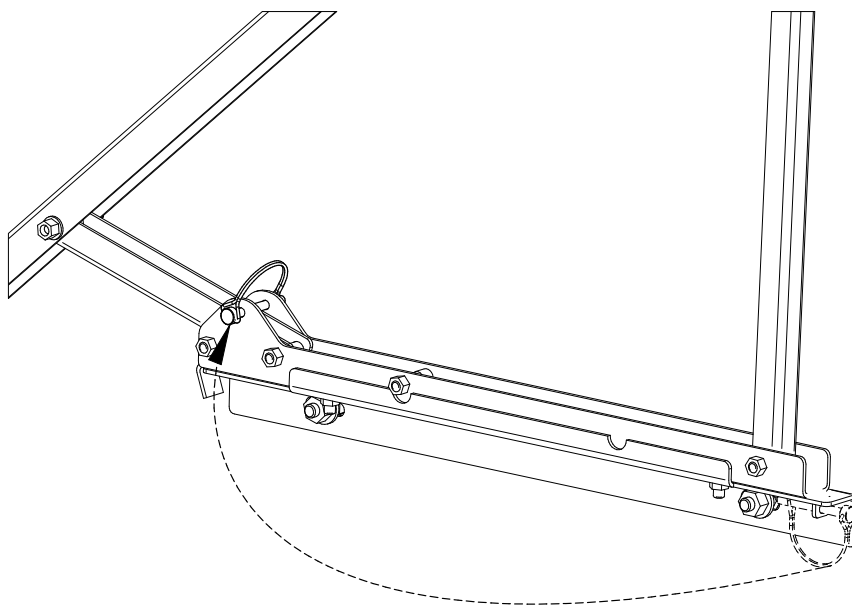
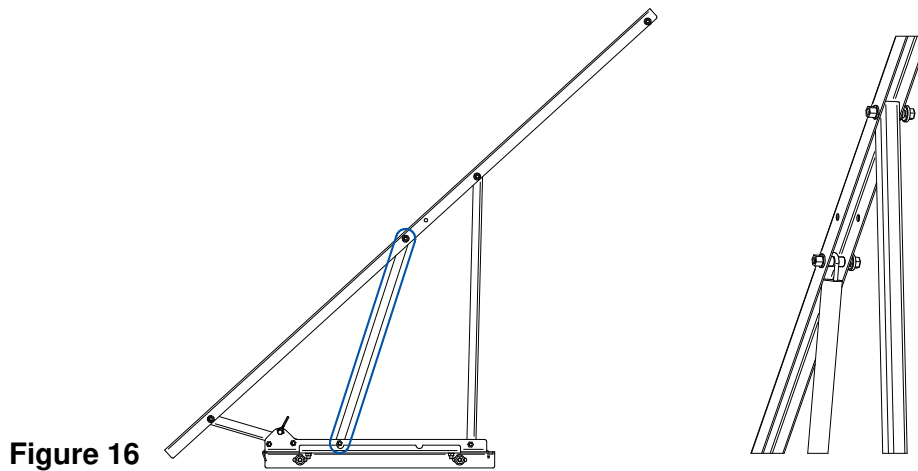

Figure 15



## 16. Spring installation.

16.1. On up to 300 series, install 3,8x21x500mm springs like shown on figure 16.



16.2. On 327 and 350 series trailers, install 5x25x570mm springs like shown on figure 17.

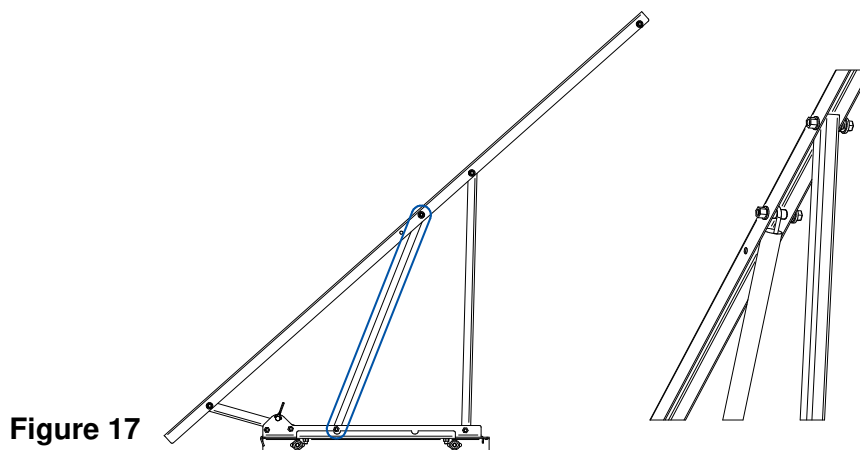

16.3. On 365 and 400 series trailers, install 3,8x21x500mm springs like shown on figure 18.

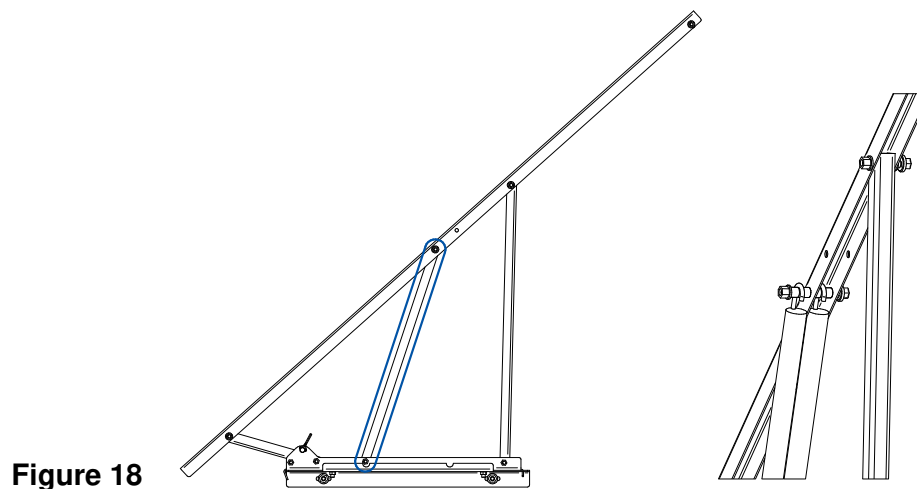



17. Place the hook latches to the back end of the trailer covers sides. Mark the mounting holes for the hook on the cover and drill them using a D7mm drill bit. Use M6x25 bolts and M6 Nylock flange nuts. **See figure 19.**

**NB!** If there is a cutout under the edge of the port, position the shutter latch inside it.

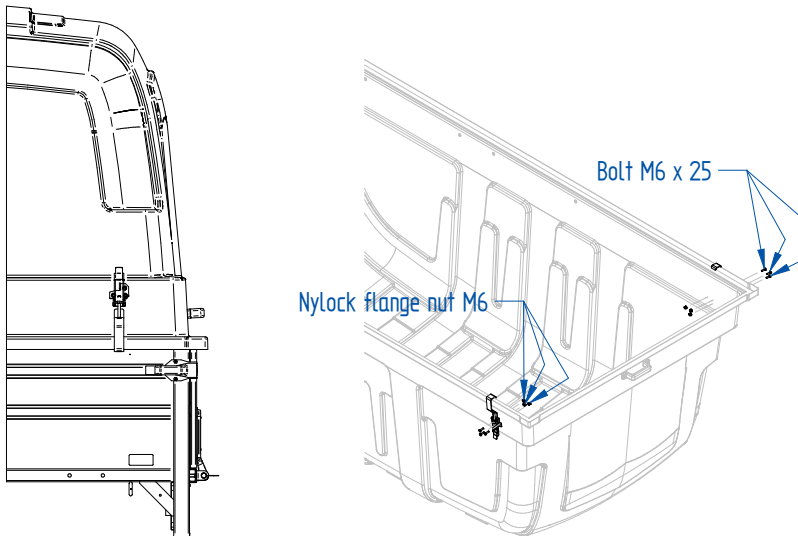

**Figure 19**

18. Adjust the hook latches length. Cover should close tightly. Place splints through the latch hook, like shown in **figure 20.**

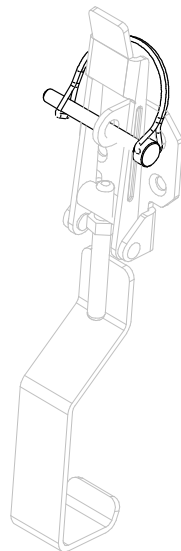

**Figure 20**